

TEPPAN-YAKI GRIDDLE/ RTYG

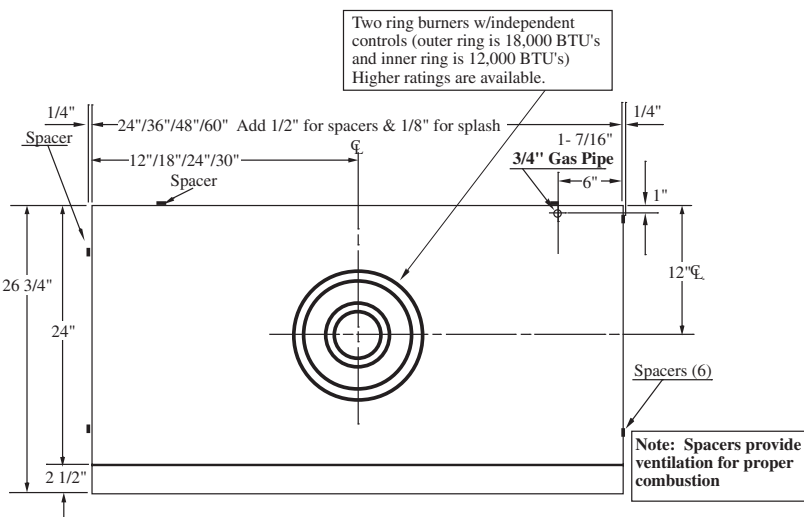
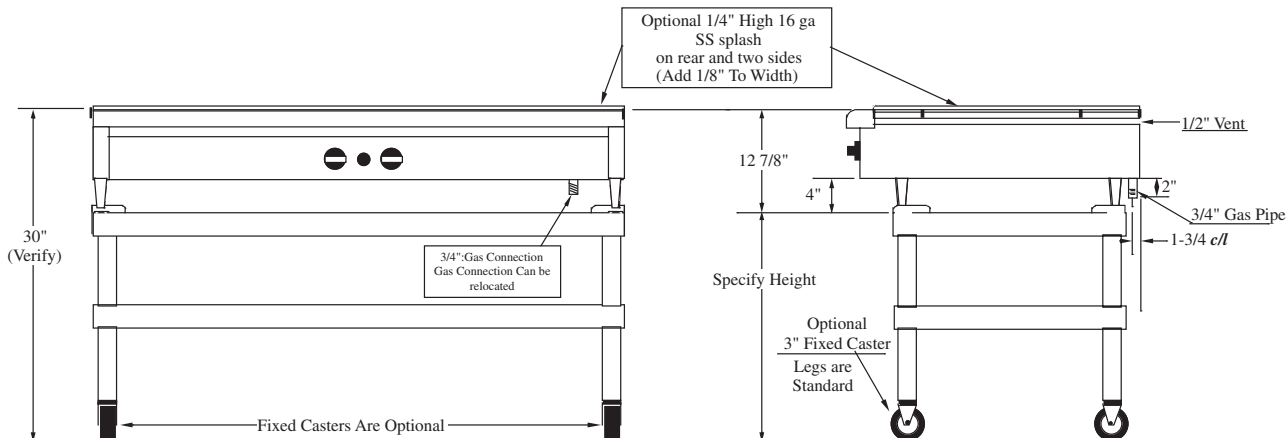

RANKIN-DELUX TEPPAN-YAKI GRIDDLE DESIGNED FOR THE JAPANESE CHEF

The Rankin-Delux Teppan-Yaki griddle incorporates the traditional Rankin-Delux quality and engineering with features not found in other makes.

The high polished cooking surface is made from steel alloys to insure consistent results over years of hard use. The optional 1/4" high stainless steel splash on the sides and rear confines the oil to the cooking surface assuring the user of a clean and sanitary preparation area.

A thick 3/4" griddle plate is furnished as standard.

The Rankin-Delux dual ring burner affords the chef complete temperature control throughout the cooking period. Both rings may be turned on to bring the cooking surface up to temperature in the shortest possible time, then the inner ring of the burner can be shut down, providing optimum performance during the cooking period. Constant pilots are standard for automatic lighting.

The Rankin-Delux Teppan-Yaki griddle is furnished with a stainless steel front.

Adjustable legs are provided to enable the user to adjust the body of the griddle for a level top surface.

TEPPAN-YAKI GRIDDLE						ADD FOR SS SPLASH	ADD FOR 2 1/2" SS GUTTER	3/4" SHIP WT. LBS	1" SHIP WT. LBS
MODEL NO.	WIDTH	O.A.DEPH	HEIGHT	3/4" PLATE	1" PLATE				
RTYG-24	24 1/2"	26 3/4"	12 7/8"	\$1,932.00	\$2,084.00	\$220.00	\$416.00	195	236
RTYG-36	36 1/2"	26 3/4"	12 7/8"	2,574.00	2,818.00	274.00	490.00	300	361
RTYG-48	48 1/2"	26 3/4"	12 7/8"	3,248.00	3,574.00	334.00	575.00	375	457
RTYG-60	60 1/2"	26 3/4"	12 7/8"	NA	4,318.00	386.00	614.00	NA	592

FURNISHED WITH PRESSURE REGULATOR
GRIDDLE MUST NOT BE SEALED TO THE COUNTER

NOTE: Safety Pilots are available at an additional cost of \$210.00. Drain trough is available at additional cost (See Above). Quick disconnects w/hoses are available (See Price List) Contact Factory for stainless steel top frame.

Signed approved drawings are required with order

Observe clearances , state, federal and all local ordinances before constructing tables.

TEPPAN-YAKI GRIDDLE STANDS					
<small>NEW Combo Stands Feature SS Tops, Plated Legs & Alum. Steel Undershelf</small>					
MODEL NO.	WIDTH	O.A.DEPH	HEIGHT	PRICE	SHIP WT. LBS
TYGS-2124	24"	21"	17" Adj	\$ 540.00	53
TYGS-2124-SS	24"	21"	17" Adj	764.00	52
TYGS-2136	36"	21"	17" Adj	678.00	64
TYGS-2136-SS	36"	21"	17" Adj	975.00	64
TYGS-2148	48"	21"	17" Adj	814.00	79
TYGS-2148-SS	48"	21"	17" Adj	1,162.00	79
TYGS-2160	60"	21"	17" Adj	1,045.00	112
TYGS-2160-SS	60"	21"	17" Adj	1,488.00	112

NOTE: Add for (4) 3" Casters \$308.00 on 24"/36"/48" Prices are for fixed (non-swivel) casters. Add for (6) 3" Casters \$466.00 on 60"

NOTE: CONTINUOUS IMPROVEMENT OF PRODUCTS IS A RANKIN-DELUX POLICY. THE COMPANY RESERVES THE RIGHT, WITHOUT NOTICE, TO MAKE CHANGES AND REVISIONS IN PRODUCT SPECIFICATIONS, MATERIALS & DESIGN, WHICH, IN THE OPINION OF THE COMPANY, WILL PROVIDE BETTER PERFORMANCE, DURABILITY AND EFFICIENCY.



ALWAYS SPECIFY TYPE OF GAS, BTU AND ALTITUDE OVER 2,000 FEET